



It is user **RESPONSIBILITY** to check that this manual (in PDF format) refers to product model and version that will be used.

In any case, regarding installation, use and maintenance, the paper-made manual given together with the product **TAKES PRIORITY.**

R.T.A. srl



**MOTION CONTROL SYSTEMS**

**PLUS B SERIES**  
**STEPPING MOTOR DRIVES**  
**INSTRUCTION MANUAL**



**R.T.A. s.r.l.**





Via E. Mattei – Frazione DIVISA  
27020 MARCIGNAGO (PV)  
Tel. +39.0382.929.855 - Fax +39.0382.929.150  
Internet: <http://www.rta.it> - e-mail: [info@rta.it](mailto:info@rta.it)

**R.T.A.  
DEUTSCHLAND GmbH**

Bublitzer Straße 34  
40599 DÜSSELDORF (Germany)  
Tel. +49.211.749.668.60 - Fax +49.211.749.668.66  
Internet: <http://www.rta-deutschland.de>  
e-mail: [info@rta-deutschland.de](mailto:info@rta-deutschland.de)



# INDEX

1 -	NOTICES AND MANUAL STRUCTURE .....	3
2 -	  LIMITATIONS, HAZARDS AND CAUTIONS .....	4
3 -	GENERAL CHARACTERISTICS AND IDENTIFICATION .....	6
4 -	INPUT AND OUTPUT LOGIC SIGNALS .....	7
5 -	INPUTS AND OUTPUTS POWER LINES .....	8
6.	DRIVE SETTING AND ALERT SIGNALS.....	9
7.	DRIVE EXTERNAL CONNECTIONS .....	13
8.	 INSTALLATION AND ENVIRONMENT LIMITS.....	14
9.	LOGIC INTERFACING EXAMPLES .....	15
10.	 APPLICATION NOTES.....	17

## Symbol meaning



The section marked with this symbol contains warnings regarding safety problems. If the directions indicated in these sections are not fulfilled, it could arise hazardous situations .



The section marked with this symbol contains information regarding operations which are strictly forbidden.



## 1 - NOTICES AND MANUAL STRUCTURE

1.1 - This manual covers the following items:

- PLUS B series stepping motor drives in all their standard versions.
- Standard characteristics of special versions of PLUS B series stepping motor drives (see chapter 1.2).
- For models and versions identification see also chapter 3.

1.2 - For the purposes of this manual the terms used assume the meaning below described (see fig. 1).

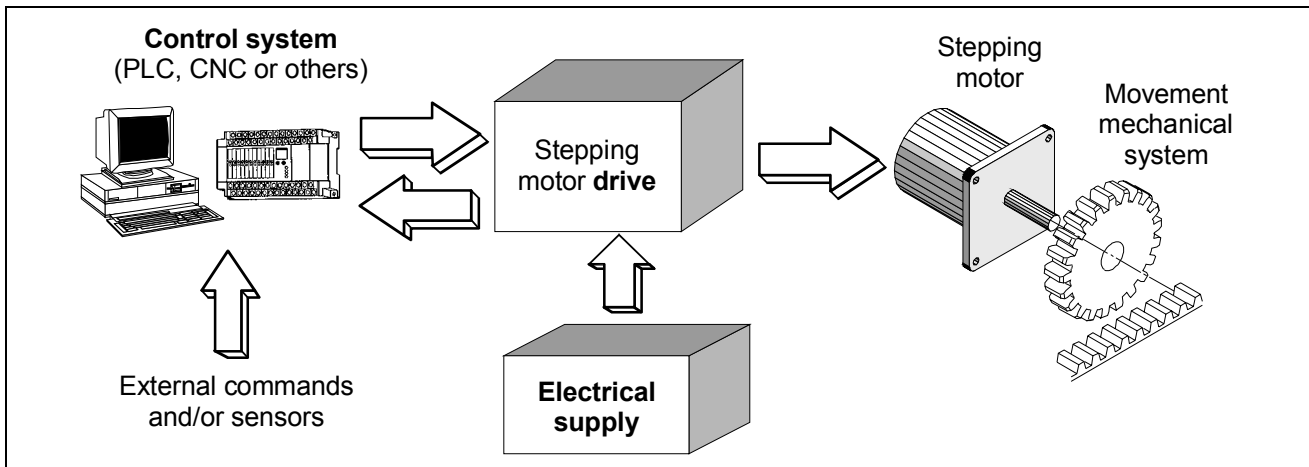

Fig. 1

- Drive: electronic part of an electromechanical motion system, which receives some digital or analog input signals from an external control system and gives to the stepping motor the suitable phase excitation sequences, in order to obtain the mechanical movements required by the control system. The drive can also communicate its status to the control system through some logic signals. In this manual we consider the drive as a BDM (EN 61800-3, chap.3, Fig.1).
- Control system: part of the machine which decides and controls all machine functions and gives to the drive all execution commands. It could be a numerical or programmable control, a personal computer or a specific control card. In the simplest machines it could also be a group of sensors and electromechanical switches.
- Electrical supply: all machine parts suitable to supply the drive in a correct way; usually filter capacitor, transformer separating from the main, anti-interference filter and all switches and protection systems.
- Standard drives are all models (see chapter 3 for identification) whose characteristics comply completely with those described in this manual. Special versions are all models in which some characteristics differ from the description given in this manual. For these models, some part of the manual does not apply and, in these cases, you must have the specific "variation sheet" which becomes an integral part of the manual itself.

1.3 - Products described in this manual (see list in chapter 1.1 and identification code in chapter 3) are CE marked and comply with the following directives:

- 1) Low Voltage (73/23/EEC and further modification).
- 2) Electromagnetic Compatibility (89/336/EEC and further modification).

1.4 - Remember that, as stated in all directives, compliance exists only when a product is used in accordance with its destination and following manufacturer prescriptions. Thereby, all relevant indications about use, cautions, installation and limitations here described must be followed by user in order to stay within compliance limits: from this point of view, chapter 2, 8 and 10 are particularly important, but the entire content of this manual has to be carefully read and considered in order to obtain the information necessary for a correct use.



- 1.5 - Conformity declaration regarding above mentioned products is kept by R.T.A. (as manufacturer residing in EEC country) together with technical construction file at authority disposal.
- 1.6 - This manual is conceived in a way to offer to the personnel involved in project and safety verification of a machine all information concerning characteristics, working conditions, application limits and cautions about PLUS B series stepping motor drives. The knowledge of this information is essential for a correct project of machines, apparatus and systems in which the drives are used, it is strongly recommended not to start any operation with the drives before you have completely read and understood the content of this manual. If you find some part of this manual not completely understandable or lacking regarding your particular application, do not hesitate to contact directly R.T.A. that can provide, if necessary, further information in order to make the user able to design his machine and the related safety systems in the best way. Take into account that an incorrect use or installation, a wrong dimensioning of external safety elements related with the drive could bring to economical damages and also to hazards for human life.
- 1.7 - Consider the fact that these are products with a very wide range of possible applications in many different working and environment conditions. For this reason this manual can only fix limits and general rules but cannot take in consideration every single possible application condition. If you have problems to understand some part of this manual or to meet its indications with your specific application, do not hesitate to contact R.T.A. for further information. Take into account that R.T.A. has twenty years of experience in any kind of applications, which cannot be condensed in a manual but can always be at customer disposal.
- 1.8 - The terms "user and customer" often used in this manual always indicate a skilled person as defined in chapter 2.9.
- 1.9 - This manual is considered valid at the moment of the selling of the product. It cannot be considered inadequate as a consequence of product or manual changes or improvements after the selling. R.T.A. reserves the right of products and manual revisions without notice neither obligation of previous products and manuals revision.

## 2 - LIMITATIONS, HAZARDS AND CAUTIONS

- 2.1 - PLUS B series drives are suitable to drive two phases stepping motors with 4, 6 or 8 terminals. Their use for different purposes is not allowed.
- 2.2 - It is not allowed the use of these drives for any purpose different from the one above indicated.
- 2.3 - It is also not allowed the use in any condition not complying with one or more specific limitations stated in this manual for electrical, mechanical and environmental quantity or characteristics.
- 2.4 - PLUS B series drives are classified as protection degree IP20 (EN60529). This means that they must be located inside a protective enclosure meeting requirements of standards applicable in the specific application in which they are used.
- 2.5 - PLUS B series drives have some dip-switches. They perform some adaptations (to the particular motor, to application, etc). **All these settings have to be made with the machine switched off, before putting it in service;** none of them requires the machine switched on.
- 2.6 - PLUS B series drives and related power supply contain capacitors able to store a certain amount of electrical energy. As a consequence, in some cases, according with application conditions and supply dimensioning, a dangerous voltage could remain on the drive, after switching off, for a time greater than 5 seconds. So it is recommended to wait an adequate time before working on the drive.
- 2.7 - The heatsink can reach high temperatures during normal working conditions (for example about 80 °C). Do not touch this component for some minutes, after switching off, in order to avoid scald hazard.
- 2.8 - After a failure due to connection mistakes or others, in the drives could arise a temporary hot spot. For this reason avoid absolutely to install in explosive or flammable environments. **Avoid also to install near easily flammable materials and components;** we recommend to verify that all the components located in the enclosure are realized using self-extinguishing materials.



- 2.9 - All products considered in this manual are sub-assemblies without a direct function, foreseen to be integrated in a more complex machine or installation by a professional assembler. PLUS B series drives are conceived for restricted distribution (EN 61800-3 Ch. 3.2). Direct use of these products by a final user is not allowed. The professional assembler using this material has to be a skilled person, adequately qualified both in the generic field of electrical and electronic systems and in the specific field of stepping motor systems. It is exclusive responsibility of the designer of the complete machine or installation in which this component is used to take care of the safety and reliability of his project. It is forbidden to use this material in application covered from one or more EEC directives (for instance 89/336/EEC, 89/392/EEC, etc.) before the conformity to those directives has been declared. Regarding 89/336/EEC directive, see chapter 10.
- 2.10 - Use for safety related functions is forbidden (EN 60204-1). Moreover, when the application arrangement is in such way that a drive fault or failure could generate a dangerous condition, external independent safety protection system must be provided in the machine.
- 2.11 - In some case of drive failure, dangerous high voltage could appear at logic low voltage input and output terminals, even if this event is extremely rare. For this reason, from the point of view of evaluation of the machine safety during a single fault condition, the external control system, connected to these inputs, has to be considered potentially subjected to high voltage, unless an external separation is provided.
- 2.12 - Both CURRENT OFF input signal (see chapter 4) and internal electronic functional protections (see chapter 6) switch off the drive output power by means of semiconductor devices. They cannot be used to interrupt power in emergency stop function or in any function involving personnel safety.



### 3 - GENERAL CHARACTERISTICS AND IDENTIFICATION

#### 3.1 - DIMENSIONS

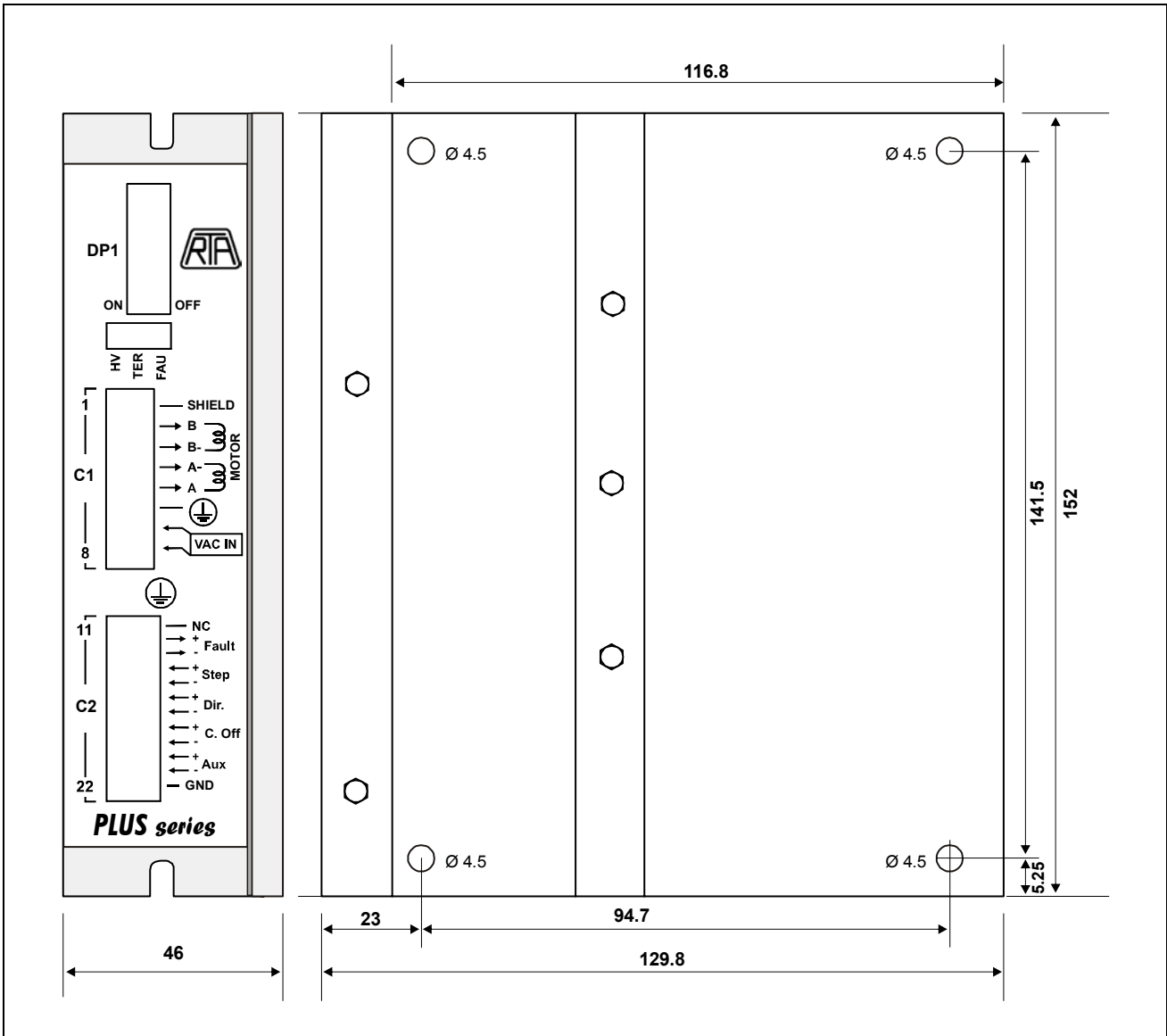

Fig. 2 – Dimensions: all measures in mm.

#### 3.2 - IDENTIFICATION

The models identification of PLUS B series drives is as follows:

**PLUS BX.Y**

where:

**X** can be: 3 or 4 and identifies a standard model, differing for current value.

**.Y** is not present in standard models. If present **Y** can be a number or an alphanumeric character identifying a special version with some variations with respect to standard models.

Each sample is also identified with a serial number.



## 4 - INPUT AND OUTPUT LOGIC SIGNALS (C2 Connector, see Fig. 2, 4 and 6)

All input and output logic signals are optically insulated among them and from internal power circuits. Positive and negative terminals are separately accessible.

- 11 Not connected.
- 12(+) e 13(-) **DRIVER FAULT OUTPUT:** When this output is SHORTED, drive is normally working; when it is OPEN drive is in no-working state. Drive automatically goes in no-working state when some protection is active and automatically recovers when the protection resets.
- 14(+) e 15(-) **STEP INPUT (STEP operation mode):** Step is performed on ON-OFF transition of this signal. Suggested duty-cycle: 50%. Max. frequency: 60 KHz with square wave signal supplied from a source with voltage between 3.5 and 13 Volt. In any case STEP signal half period has to be higher than 8  $\mu$ sec.
- ENABLE INPUT (RUN operation mode):** When this signal is ON, motor rotate in the direction set by DIRECTION signal. When this signal is OFF the motor stops. The maximum delay at enabling or disabling is lower than 1.5 millisecc. In the case of a revolution time lower than 20 millisecc, command circuit has to be realized very carefully. In this case to contact RTA is highly recommended.
- 16(+) e 17(-) **DIRECTION INPUT:** if this signal is ON, the motor rotation direction is opposite to the one obtained when this input is OFF. This signal has to be set up at least 100  $\mu$ sec before STEP signal and has to stay in this state for at least 100  $\mu$ sec after last STEP sent to the drive.
- 18(+) e 19(-) **CURRENT OFF INPUT:** when this signal is ON drive is active. When it is OFF drive is inhibited, thus motor current (and so holding torque) is turned to zero. When dp1 in DP2 DIP-SWITCH is set ON, this input is shorted in ON position.
- 20(+) e 21(-) **AUX INPUT:** This input is used to enable function of internal steps multiplier by four. When this signal is ON steps multiplier is active.
- 22 **INTERNAL GND:** This terminal is galvanically insulated from logic inputs and outputs and it is internally connected to terminals 1 and 6 of C1 connector. It can be used to connect the shield of logic signal cable (this is mandatory or useful, depending on type of control system).

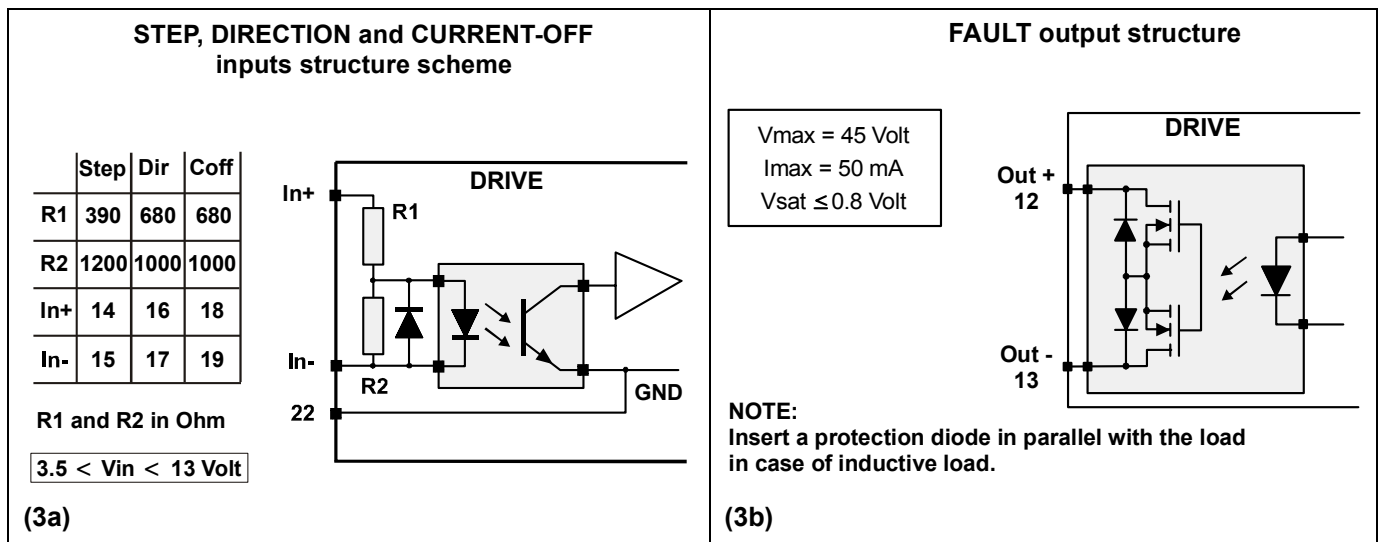

Fig. 3 – Inputs and outputs scheme.



## 5 -INPUTS AND OUTPUTS POWER LINES

In this chapter drive inputs and outputs power lines and the required power supply lines are described.

5.1-Drive power outputs are the four phase lines driving the stepping motor winding. Drive power inputs are the two connection lines to  $V_{ACnom}$ . All connector C1 terminals are listed in the following Table 1.

TABLE 1	
CONNECTOR C1	DESCRIPTION
1	Shield of shielded motor cable
2	Motor winding terminal B
3	Motor winding terminal B-
4	Motor winding terminal A-
5	Motor winding terminal A
6	GND
7, 8	Power supply

5.2-Earth terminal – Earth terminal is on the frontal panel in the middle of it and has to be electrically connected to earth (PE terminal of the machine in which the drive is installed).

5.3-The terminal indicated as GND is the point of motor-drive system that has to be connected to earth (PE terminal) in order to guarantee the correct operation of some drive protection systems. No other point at a different potential of logic circuit and of power circuit has to be connected to earth; in particular has not to be connected to earth transformer secondary winding. Other points at the same potential of GND could be connected to earth using the cautions suggested by well known techniques, to obtain a correct location of multiple earth connections. Shielded cables both of logic signals and motor outputs must be connected to points at the same potential as GND. Furthermore it is important to note that GND terminal is internally connected to terminal 1 of C1 and to terminal 22 of C2. See connection schemes of fig. 6, 11 and 12.

5.4-Table 2 shows power inputs and outputs characteristics:

TABLE 2		PLUS B3	PLUS B4
$V_{AC nom}$	(VOLT)	from 25 to 62	from 50 to 100
$I_{NP min}$	(AMP)	2.4	1.9
$I_{NP max}$	(AMP)	8	6
Phase inductance	(mH)	from 0.8 to 12	from 1.2 to 12
Dimensions	(mm)	152 × 129 × 46	
Operating temperature		from +5°C to +40°C (see chap. 8.3)	

5.5-Definition of terms used in Table 2:

- $V_{AC nom}$ : RMS value of alternate voltage at which the drive can be supplied.
- $I_{NP}$ : indicates nominal phase current (peak value), which flows in each motor winding, it can be measurable with motor turning at **low speed**. The drive provides an automatic current reduction when the motor is in hold condition. Phase current is calibrated during the test phase and can be set by the customer, choosing between eight different values, by means of DIP-SWITCHES.
- $I_{NP min}$  and  $I_{NP max}$ : minimum and maximum nominal phase current value which can be set by user using DIP-SWITCHES.



## 6. DRIVE SETTING AND ALERT SIGNALS

- 6.1- PLUS B series drives are general purpose products which can be used to drive many different motor models in different kind of applications. For this reason they have eight two-positions DIP-SWITCH suitable to adapt drive characteristics to the specific motor and/or application. **The setting of this dip-switch has to be made by customer before putting in service the drive. Do not forget to do these settings: wrong setting could get application errors and also motor damages and hazard conditions.** Three led indicate the drive status.
- 6.2- Fig. 4 shows the position of DIP-SWITCH DP1, alert LED, connectors and labels in PLUS B series drives.

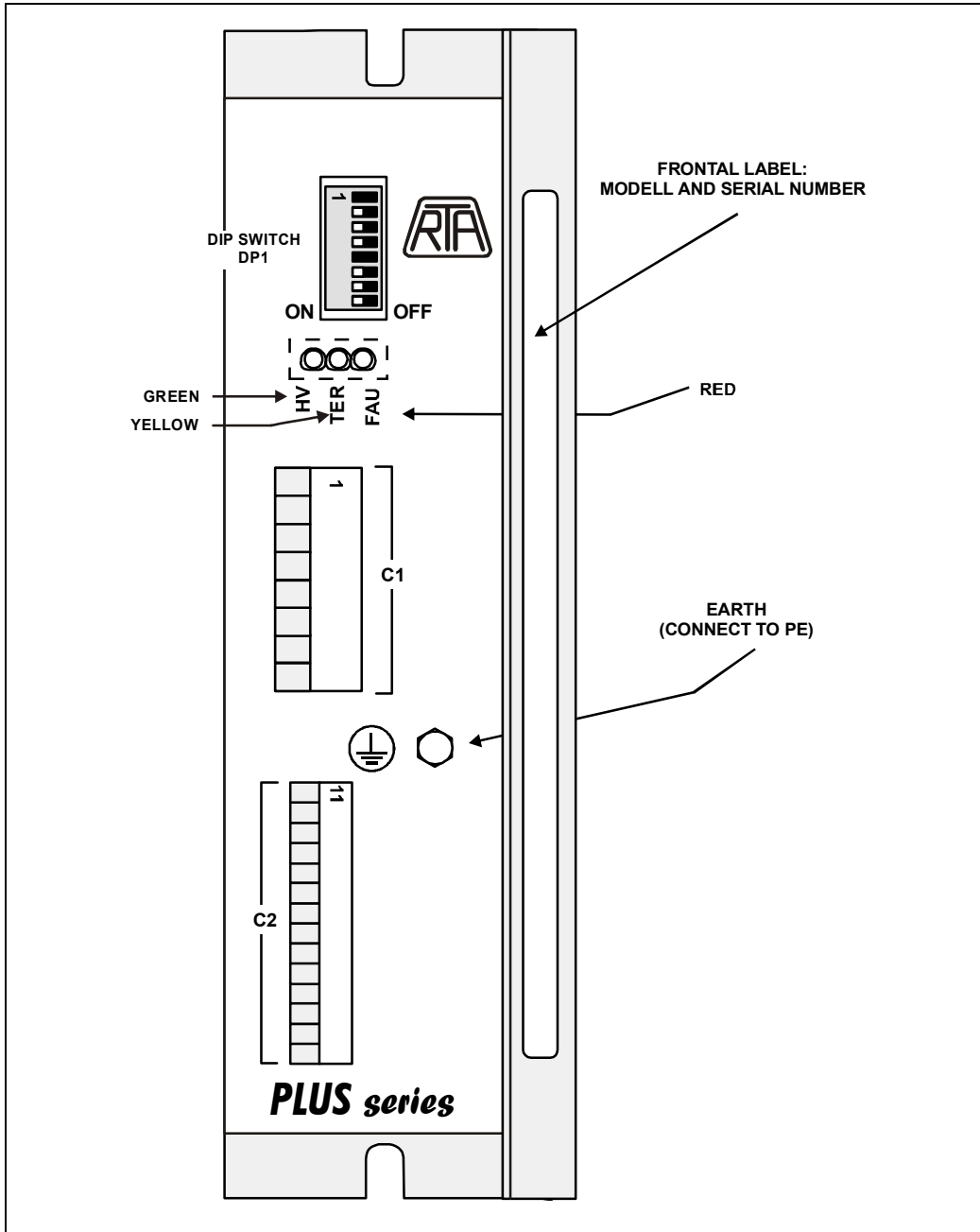

Fig. 4 – Dip-switch DP1, alert led and connectors.



6.3-Fig. 5 shows the position of DIP-SWITCH DP2 located on the bottom side of PLUS B series drives.

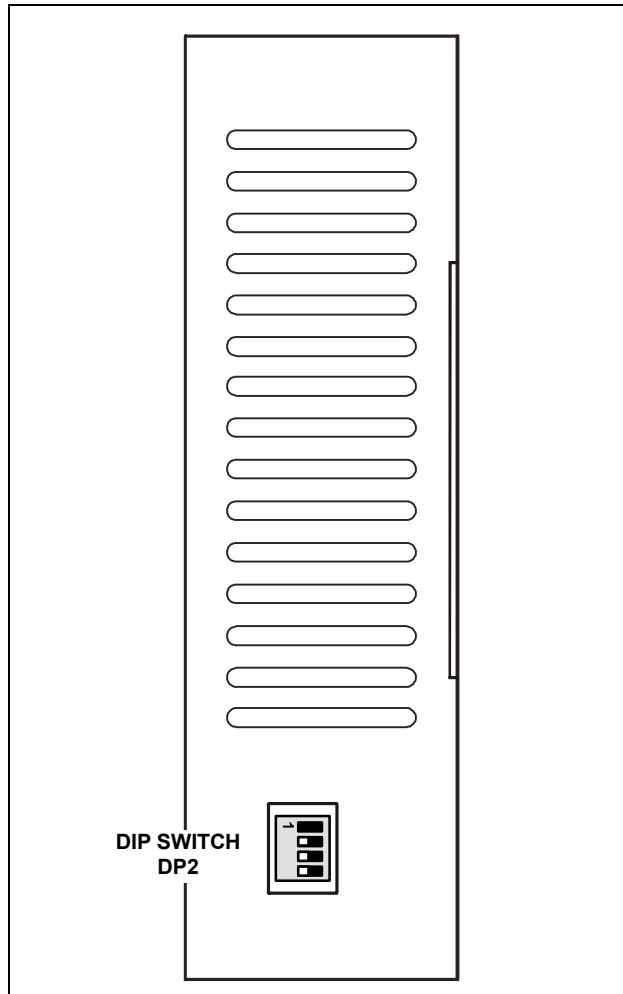

Fig. 5 – Dip-switch DP2 (PLUS B series drives bottom side view).

6.4-MAIN SETTINGS DIP-SWITCH DP1

Table 3 shows the position of dips 1, 2 and 3 (DP1) and the related motor nominal current.

DP1			NOMINAL CURRENT $I_{NP}$ in Ampere	
Dip 1	Dip 2	Dip 3	PLUS B3	PLUS B4
ON	ON	ON	2.4	1.9
ON	ON	OFF	3.1	2.3
ON	OFF	ON	3.6	2.7
ON	OFF	OFF	4.3	3.1
OFF	ON	ON	4.5	3.6
OFF	ON	OFF	5.7	4.3
OFF	OFF	ON	6.8	5.1
OFF	OFF	OFF	8.0	6.0

Table 3



Table 4 shows the position of dip 4 (**DP1**) and the corresponding damping mode.

<b>DP1</b>	<b>DAMPING</b>
<b>DIP 4</b>	
ON	ENABLE
OFF	DISABLE

Table 4

Damping electronic circuit ensures low acoustic noise and reduces the amount of typical stepping motor mechanical vibrations. In any case, these can be reduced using higher values of steps /revolution in accordance with the maximum frequency produced by control system and with maximum revolution speed requested to the motor.

For example, in the case of control system generating a maximum frequency of 10 KHz and if the desired speed is equal to 600rpm = 10 revolutions/sec, 1000 steps/rev (=10.000/10) is the maximum resolution that can be used.

#### 6.5-MAIN SETTINGS DIP-SWITCH DP2

Table 5 shows the position of dip 1, 2, 3 and 4 of **DP2** (see Fig. 5) and the corresponding operation mode.

<b>DP2</b>				<b>OPERATION MODE</b>
<b>DIP 1</b>	<b>DIP 2</b>	<b>DIP 3</b>	<b>DIP 4</b>	
ON	-	-	OFF	Current off input forced to ON
OFF	-	-	OFF	Current off input set by external signal
-	ON	-	OFF	Automatic current reduction disable
-	OFF	-	OFF	Automatic current reduction active
-	-	ON	OFF	RUN operation mode
-	-	OFF	OFF	STEP operation mode

Table 5

#### 6.6-STEP operation mode (dip 3 of DP2, in position OFF)

Table 6 shows the available steps/rev values corresponding to each specific dip (5, 6, 7 and 8 of **DP1**) configuration.

<b>DP1</b>				<b>STEPS FOR REV.</b>
<b>Dip 5</b>	<b>Dip 6</b>	<b>Dip 7</b>	<b>Dip 8</b>	
OFF	ON	ON	ON	4.000 x
OFF	ON	ON	OFF	2.000 x
OFF	ON	OFF	ON	1.000
OFF	ON	OFF	OFF	500
OFF	OFF	ON	ON	3.200 x
OFF	OFF	ON	OFF	1.600 x
OFF	OFF	OFF	ON	800
OFF	OFF	OFF	OFF	400

Table 6

▶ = default factory setting.

X = operation mode which allows internal STEP multiplier function (by AUX input enable).



### 6.7-RUN operation mode (dip 3 of DP2, in position ON)

DP1				MOTOR SPEED	
Dip 5	Dip 6	Dip 7	Dip 8	STEPS FOR REV.	RPM
ON	ON	OFF	OFF	400	450 (R)
ON	OFF	OFF	OFF	400	338 (R)
OFF	ON	OFF	OFF	400	225 (R)
OFF	OFF	OFF	OFF	400	113
ON	ON	OFF	ON	800	225 (R)
ON	OFF	OFF	ON	800	169 (R)
OFF	ON	OFF	ON	800	113 (R)
OFF	OFF	OFF	ON	800	56
ON	ON	ON	OFF	1600	113 (R)
ON	OFF	ON	OFF	1600	84 (R)
OFF	ON	ON	OFF	1600	56
OFF	OFF	ON	OFF	1600	28
ON	ON	ON	ON	3200	56 (R)
ON	OFF	ON	ON	3200	42
OFF	ON	ON	ON	3200	28
OFF	OFF	ON	ON	3200	14

**Table 7**

DIP SWITCHES 5 and 6 set the oscillator frequency, DIP SWITCHES 7 and 8 set the resolution in steps/rev. The character **(R)** indicates a linear acceleration when motor starts and stops (micro-ramp) to improve the START - STOP performance. PAY ATTENTION: In case of dip configurations giving equal rpm speed, some of them settings enable micro-ramp but others not enable micro-ramp. The choice of the configuration giving higher steps/rev produces rotations with less noise and with lower mechanical vibrations.

**NOTE:** when automatic current reduction is active, the current which flows in each motor winding is reduced to 50% of nominal current value nearly 50ms after the stop of the motor, in both STEP and RUN operation modes.

6.8-The following list shows the meaning of the alert LEDs.

**LED HV (green):** ON = supply voltage is in the correct operating range.

OFF = drive is not supplied or supply voltage is out of the correct range (in the second case also LED FAU is ON).

**LED FAU (red):** ON = drive is in no-working state due to one of the following protection:

- a-Thermal protection (if LED TER is ON).
- b-Max or Min supply voltage (if LED HV is OFF).
- c-Short circuit or wrong motor connection (if LED HV is ON and LED TER is OFF).

OFF = drive is in working state if LED HV is ON.

**LED TER (yellow):** ON = drive is in no-working state by thermal protection (in this case LED FAU is ON).

OFF = heatsink temperature is lower than the limiting value.

BLINKING:

- 1 FLASH = Min/max voltage protection memory
- 2 FLASHES = Thermal protection memory
- 3 FLASHES = Short circuit protection memory
- 4 FLASHES = Motor cable not connected (active with motor in stop state only)

All protection circuit and alarm reset itself when the alarm source vanish. Memory must be reset by removing power supply voltage.



## 7. DRIVE EXTERNAL CONNECTIONS

- 7.1- Design the power transformer: the power of transformer has to be higher than the sum of the power requested from drive and motor (total power). This one can be calculated as the sum of the following terms:
- Mechanical power delivered to load: mainly depending on application characteristics like friction, inertia, efficiency of mechanical transmission etc.
  - Motor losses: mainly depending on motor type, drive voltage, speed and duty cycle.
  - Drive losses: mainly depending on drive model, current setting and duty cycle; according with these parameters these losses can approximately vary between 60 and 130 Watt. It is often very hard to estimate drive and motor losses; in this case an over-dimensioning of the supply elements proportional to the inaccuracy is recommended. To get more accurate information, contact R.T.A. and describe the particular application. Obviously if a single power supply is used for more than one drive, the total power is equal to the sum of the single drive powers.
- 7.2- Transformer must meet the following requirements:
- Supply the correct voltage through a transformer secondary winding. The  $V_{AC}$  voltage value is intended as measured at secondary terminals in no load condition and with primary voltage equal to the nominal value. Maximum voltage drop at full power load must be less than 5%.
  - Ensure the galvanic insulation between the drive circuits and the main. **Remember that direct connection of drive circuits to the main is strictly forbidden. The use of autotransformer is strictly forbidden.**
  - Ensure the galvanic insulation between the drive circuits and all other circuits of the same machine. **This means that the drive dedicated transformer secondary has to be used exclusively for the drive.**
- 7.3- The use of one secondary winding for more drives (max 3 drives) is allowed only if the total power required by the drives is less than 600VA. In any case, two fuses (F1 and F2 showed in Figure 6) for each drive must be used.
- 7.4- **Branch circuit protection fuses F1 and F2 (see Fig. 6) must be 10 Amp, at least 250 Volt with  $I^2t$  between 150 A<sup>2</sup>s and 400 A<sup>2</sup>s (for example Cooper Bussman model KTK-R-10 or Littelfuse 215010.P).**
- 7.5- The cross-section area of conductors used in power supply circuit must be chosen according with power dimensioning (see 7.1). The cross-section area of the four shielded conductors connecting motor to the drive must be chosen with regard to the nominal current which has been set in the drive.

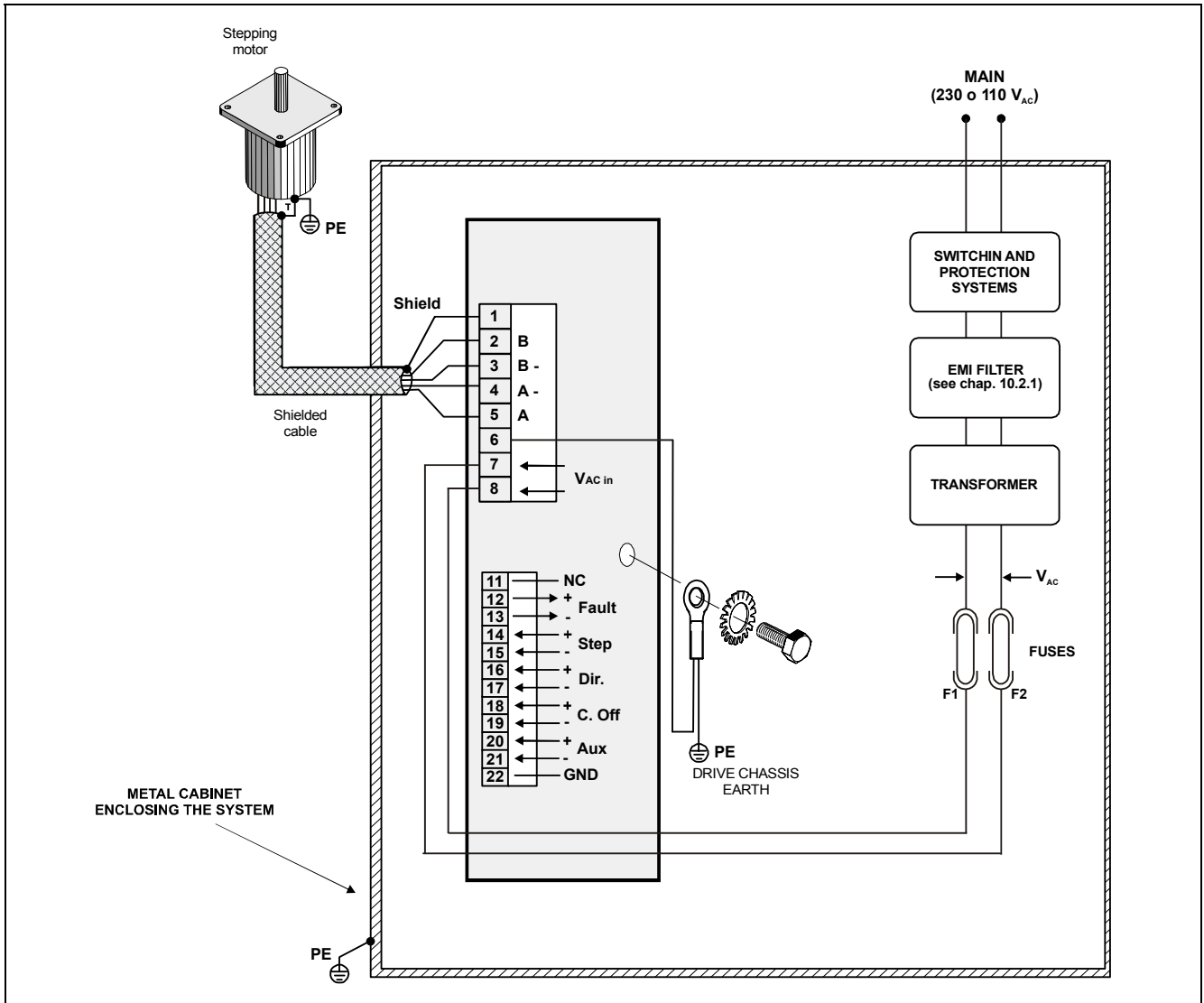

Fig. 6 – Drive external connections scheme.

## 8. INSTALLATION AND ENVIRONMENT LIMITS

All products described in this manual are subjected to the following characteristics:

8.1-IP20 (EN 60529) protection degree: it is user responsibility to provide an adequate protection enclosure suitable to meet the standards regarding the specific application in which the products are used.

8.2-Direct connection with the main is not allowed. Transformer separation is mandatory.

8.3-Installation and work environment. Installation is allowed in a micro-environment with:

- **Environment conditions class 3K3** (IEC 721-3-3): it includes a working temperature from +5°C to +40°C and relative humidity from 5% to 85% non condensing.
- **Pollution degree 2** (IEC 664-1): it includes that installation in environments in which explosive and/or flammable and/or chemically aggressive and/or electrically conductive gas, vapor or dust could be present is strictly forbidden.
- **Mechanical conditions class 3M1** (IEC 721-3-3).

If the environment in which the machine is used does not satisfy these conditions, suitable conditioning system or suitable case have to be used.



8.4-Storage environment limits with drive in its original packaging:

- Temperature: from -25°C to +55°C. Relative humidity: from 5% to 95%.
- Environment conditions class 1K3 (IEC 721-3-1). Pollution degree 2.

8.5-The drive generates some amount of heat (see chap. 7.1). This must be considered during the global electrical cabinet design. In order to ease air flowing around the drive, install the drive vertically (not turned upside down) with at least 5 cm of free space over and under the drive and 1 cm on the left and on the right of the drive. Do not obstruct air gratings.

## 9. LOGIC INTERFACING EXAMPLES

In this chapter some interfacing techniques are shown. They have to be considered only as examples. The best way to interface the drive with the control system can be chosen only with a complete knowledge of the control system and application requirements.

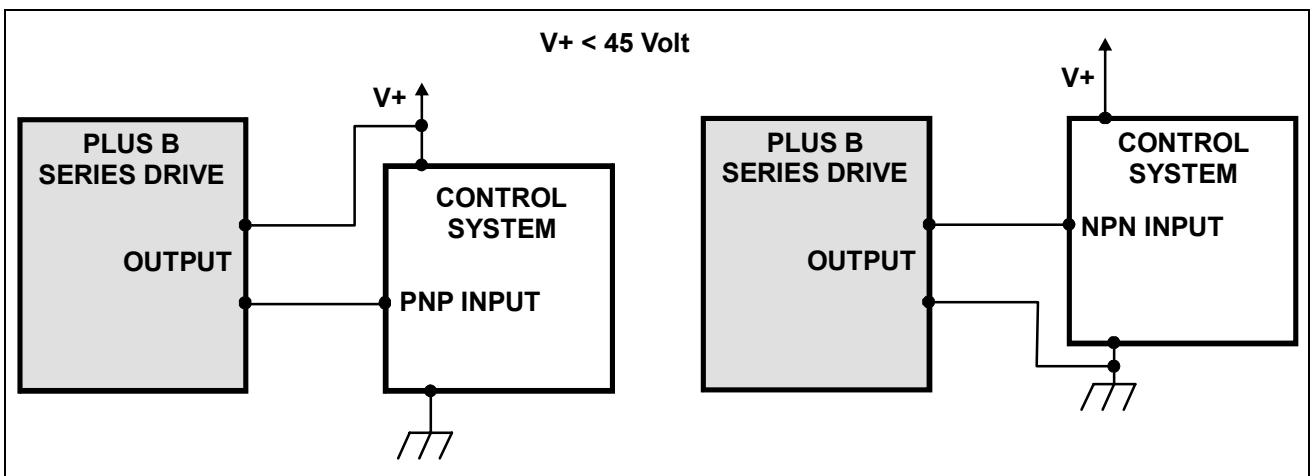

Fig. 7 – Electric connection between a PLUS B logic output and an input of a control system operating at  $V+$  voltage.

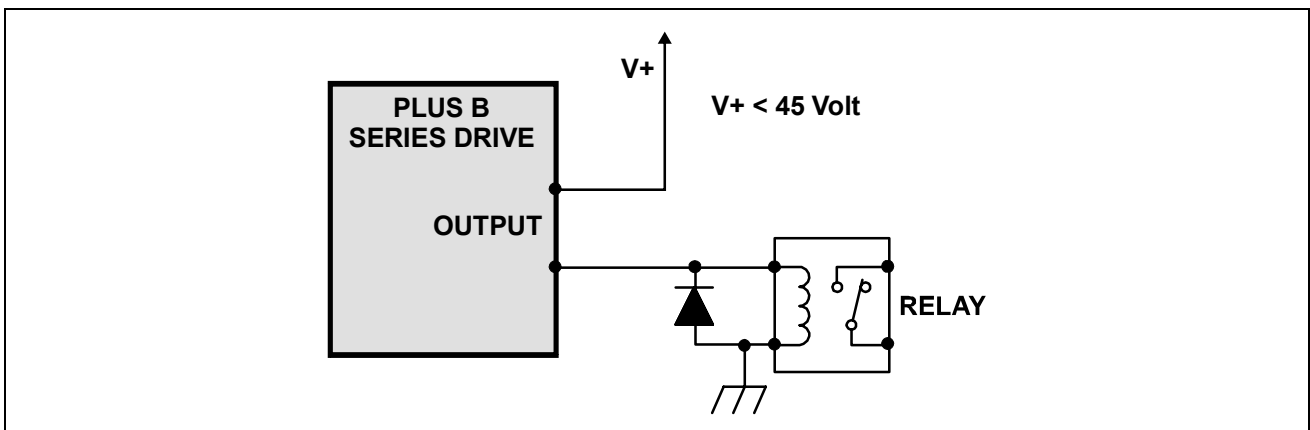

Fig. 8 - Driving a micro-relay by means of a PLUS B logic output.

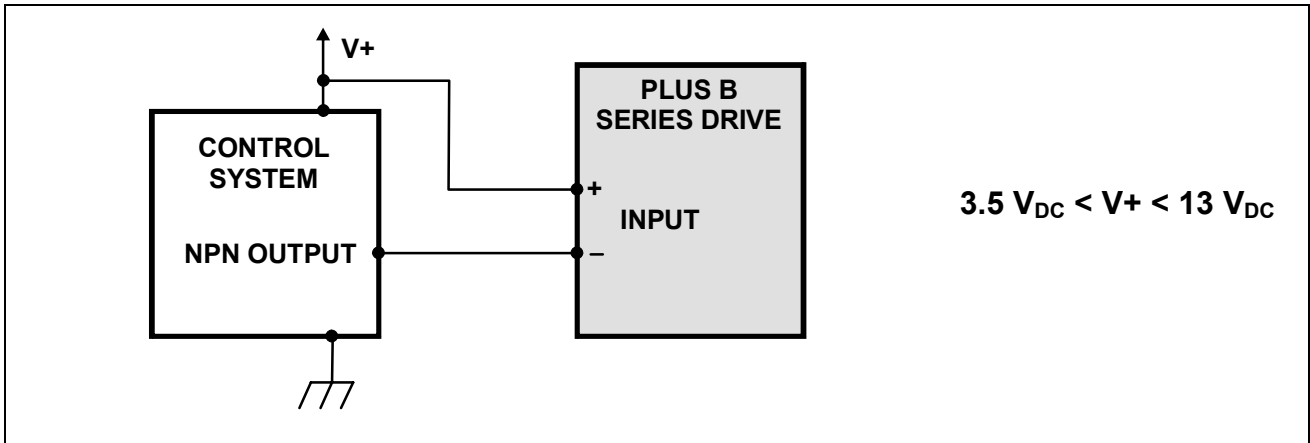

Fig. 9 - Driving a PLUS B logic input from a control system with a NPN open collector output.

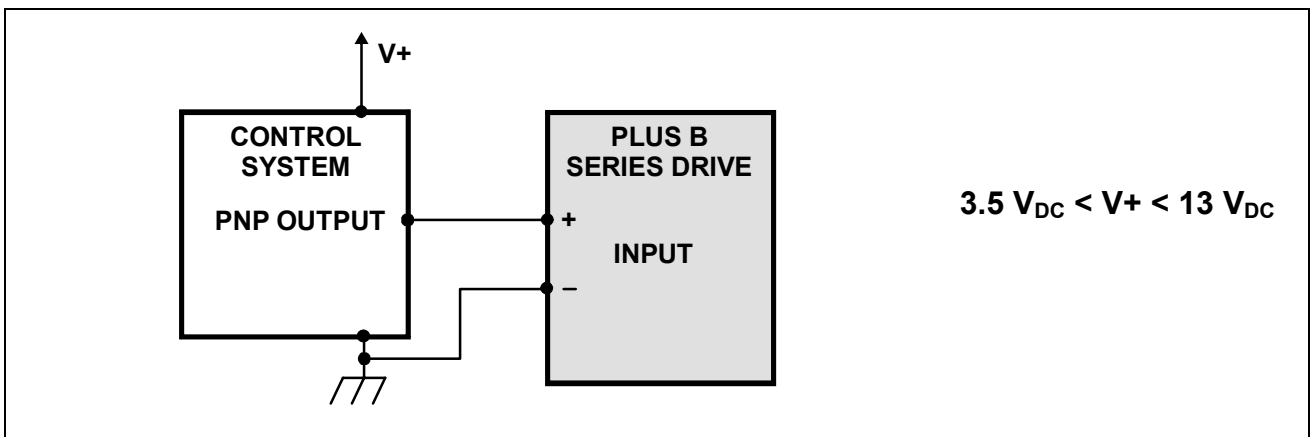

Fig. 10 - Driving a PLUS B logic input from a control system with a PNP output.

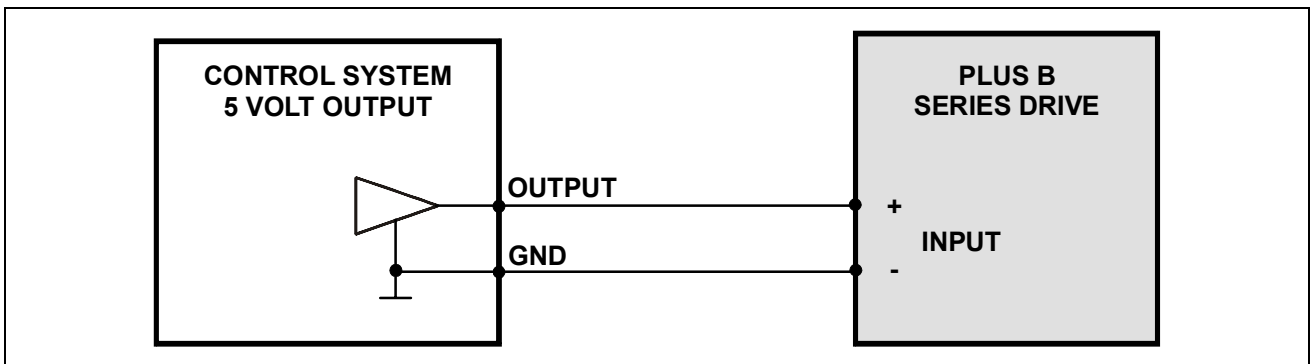

Fig. 11 - Connection example with control system with 5 Volt TOTEM-POLE (PUSH-PULL) output.

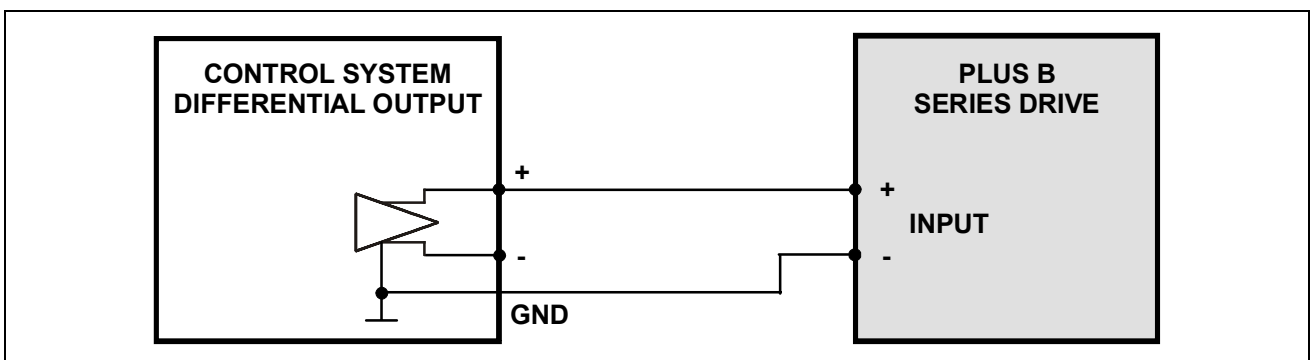

Fig. 12 - Connection example with control system with DIFFERENTIAL output (or LINE DRIVER or RS422).



## 10. APPLICATION NOTES

- 10.1- Drive (or drives) power supply can not be used to supply other machines.
- 10.2- PLUS B series drives are BDM (Basic Drive Module) conceived for restricted distribution (EN 61800-3). This means that R.T.A. has the responsibility to verify the products compatibility in some typical way of use in order to give correct installation information. In any cases, it is responsibility of the professional assembler, who installs this product, to verify the compatibility of the complete machine or system.

10.2.1- The set consisting of drive, motor, transformer and all related cablings are source of electromagnetic interferences. The assembler of installation must consider these problems during the project of the plant where the drive (or drives) will be installed in order to shield and/or reduce these interferences. Tests performed by R.T.A. show that the most effective measures able to reduce these interferences are the following:

- Shielding of cables for the connection between motor and drive. The shield of this cable has to be directly connected to PLUS B series drive terminal 1. This shielding can be avoided only in case of very small and compact machine where motor, drive and related connections are located in the same enclosure, showing adequate shield performance.
- Connect earth line to motor chassis. To reduce the radio-frequency emissions, the mechanical connection of motor to machine chassis (by means of mounting flanges and screws), is typically simple and effective solution. In this case, both screws and chassis must be of conductor material and the chassis must be connected to earth. See fig. 11.
- Location of motor-drive set in the same cabinet shielded from electromagnetic interferences.
- Use a power supply transformer with a metallic shield, connected to earth, interposed between primary and secondary winding.
- Interpose a filter between the transformer primary and the main (220 or 380 V<sub>AC</sub>). The filter is used to reduce conducted electromagnetic interferences. Filter characteristics in a specific installation depend on the following factors:
  - The specific standard limits the machine (in which drive is used) is subjected to.
  - Power level of application (voltage and current setting of the drive).
  - Presence of other filtering systems in the general electrical machine connections.

In any case, the following filter types are recommended:

- CORCOM VDK series for single-phase power supply.
- CORCOM FCD10 series for three-phase power supply.

Different types of these series differ for current rating. Choose the specific model according to the power level of the specific installation.

- Consider that the position of the filter in the system is extremely important: no electromagnetic coupling must take place between electromagnetic source and circuits (and lines). To this end, filter and main must be kept as close as possible.
- All earth connections mentioned above have to be realized with the less possible inductance.

10.2.2- To improve the drive logic input signals immunity from external noise the following well known procedures, to manage the relatively fast signals treatment must be considered:

- Use shielded cables with shield connected to terminal 22.
- When cables length exceeds 5-6 meters, prefer "buffer" type driving signals instead of "open collector" type.
- Keep signal cables separate from power cables. In particular keep signal cables separate from motor output cables.
- Carefully verify logic level compatibility when interfacing drive with control system.



10.2.3- Following these procedures is essential to realize an installation which complies with the requirements of 89/336/EEC directive. The real specific standard compliance have to be proved in the complete installation. In fact the effectiveness of the suggested application notes depends also on machine topology and on the measurement setup. Test performed by R.T.A. simulating typical installations and following the mentioned above indications show that EN61800-3 standard compliance applications can be achieved.

10.2.4- In some cases, due to the characteristics of particular installations, conflicts between ground connections necessary for shielding purposes and ground connections necessary for safety reasons could arise. Remember that, in such cases, prescriptions regarding safety take priority, but remember also that, in almost all of the cases it is possible to find a solution meeting both prescriptions; R.T.A. is available for further information about these problems.

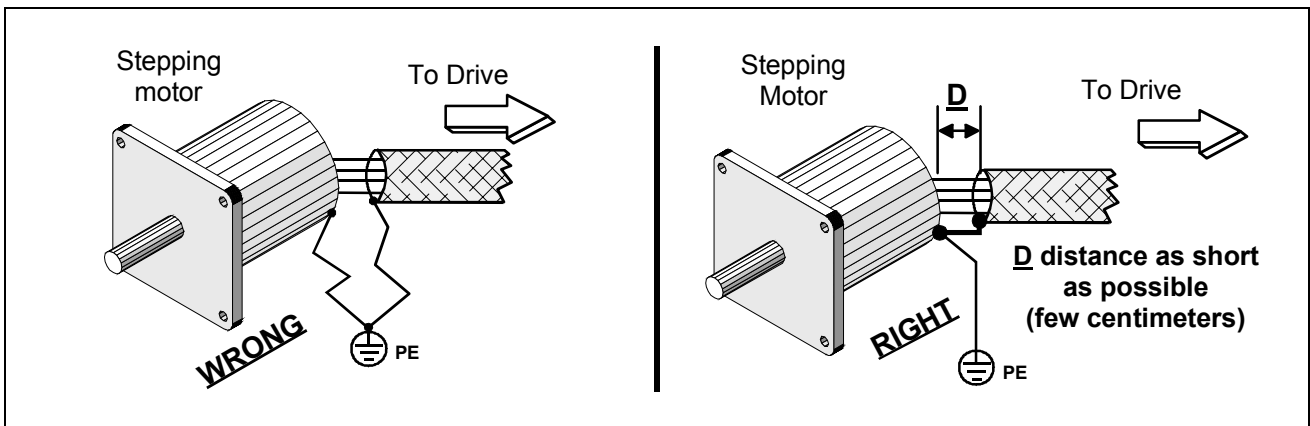

Fig. 11 - Shielded connection at stepping motor side.

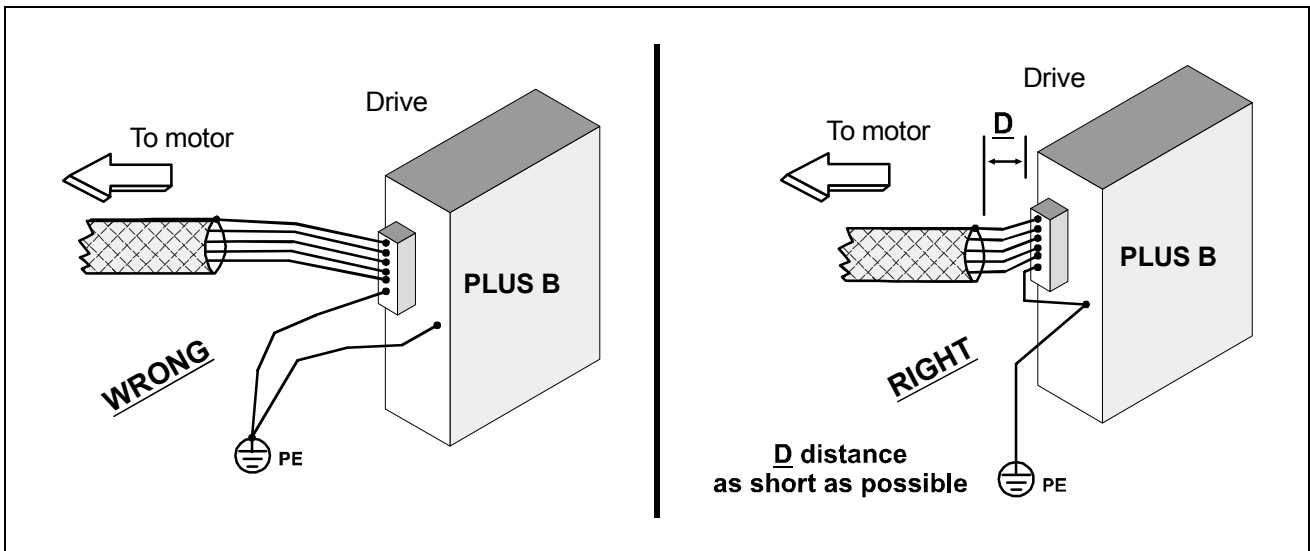

Fig. 12 - Shielded connection at drive side.